

S-670 Stealth Series™ Shaft Alignment Systems

S-670 3-Axis Wireless



**HAMAR
LASER**®

Shaft Alignment Laser Systems

S-670 Wireless 3-Axis Shaft Alignment System

The S-670 is a next-generation shaft alignment laser system and part of the new Stealth Series™ developed by Hamar Laser Instruments, Inc.

The S-670 uses the latest in super-linear PSD technology, wireless communication and innovative design to offer the most feature-rich, accurate, and reasonably priced system on the market today. With over 40 years of laser alignment innovation, our systems can easily be used by the most inexperienced millwright but are also highly advanced for the most experienced users.

Features

- **Bluetooth® Wireless Communication:** Internal Bluetooth transmitter with a range from Target to PDA of up to 33' (10 M).
- **Super-Linear PSD Detector Technology:** 1-axis super-linear PSD technology provides 1 micron resolution with a measuring range of 30 mm (V) x 8 mm (H).
- **2-Axis Live Move Screen:** Offset and angular alignment values continuously update and dynamic motor graphics show how much the motor moves as you adjust it!
- **Long Wireless Battery Life:** Laser and target use the latest in lithium polymer battery technology, which offers the industry's longest wireless battery life of over 12 hours of continuous use!
- **Latest Electronic Design:** Both laser and target are newly designed and incorporate the most sophisticated electronics available.

- **Auto Sweep™ Data Taking Mode:** A standard feature, making coupled alignment amazingly easy. Built-in accelerometer detects movement and automatically sends data to the software without pushing any buttons.

The S-670 offers an array of standard and optional hardware to help you get the most from your shaft alignment system.

Laser

The S-670 Laser uses patented Dual-Beam™ Technology that allows the measurement of offset and angle simultaneously with one PSD, thus eliminating potential measurement errors when using two PSD's.



Target

Target Resolution is 1.0 micron (Offset) and 0.02 mm/M (Angular), with an Angular Sensor Range of +/- 5 degrees.



- **Standard Brackets:** Bracket kit comes with enough chain to align 1" (25.4 mm) to 6" (152.4 mm) diameter shafts, and 4" (101.6 mm), and 8" (203.2 mm) posts. With our optional A-981 Adapter Bracket you can use the S-670 on our competitor's standard brackets!
- **Ruggedized PDA:** High resolution screen, 15-hour battery life and 512 MB of memory. Options include Digital Camera, Bar Code Scanner, GPS, AA Battery Module, Wireless LAN and many more.

- **Uncoupled Mode:** Utilizing the Auto Sweep™ function, uncoupled alignments are fast and easy: rotate the laser to any point, sweep the target by, and the software automatically records the measurement.
- **More Standard Features:** Wireless communication, Auto Sweep™, Thermal Growth, Recommended Tolerance and several more features are included in the standard package... unlike our competitors.
- **High Accuracy:** Up to 5x higher PSD accuracy than our competitors, the S-670 gives you one of the most accurate measurements on the market.

Standard Hardware

- Bluetooth® Wireless Communication
- 1.0 Micron Resolution
- <0.3% Offset Measurement Accuracy
- 30 mm x 8 mm Single-Axis PSD
- New Lithium Polymer Battery Technology
- 12-Hour Wireless Target Battery Life
- Dual-Beam™ Technology
- State-of-the-Art Electronics
- Ruggedized PDA with 15-Hour Battery Life and IP67 Rating
- Standard Bracket for 1" to 6" (25.4 mm to 152.4 mm) Shaft Diameters

Optional Hardware

- Magnetic bracket
- Offset bracket
- Non-rotating shaft bracket
- Bolt-hole bracket
- Small-shaft adapter
- Stealth interactive training video

The Best Choice in Shaft Alignment is Easy To See

Easy-to-Follow Screens Lead You Through the Alignment



Select Machine – Select alignment and coupling type.



Dimensions – Enter only 4 motor dimensions for automatic shim value calculation during the alignment.



Soft Foot Results – Easy to follow procedure for checking Soft Foot, a common problem that can cause many alignment problems.



Take Readings – 4 data taking modes for maximum flexibility and ease of use: Autosweep™ Mode, Point Mode, Uncoupled Mode or Clock Mode.

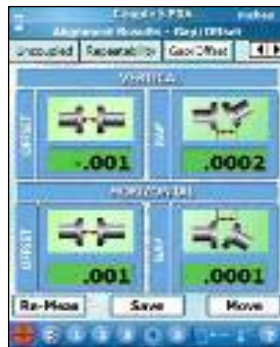

Results Screen – Shows misalignment results instantaneously. Green means in tolerance and red means out of tolerance.



Move Screen – Live in both offset and angular axes, the Move Screen instantaneously shows the movement of the motor during alignment making it easy to align the motor.

Sample Report

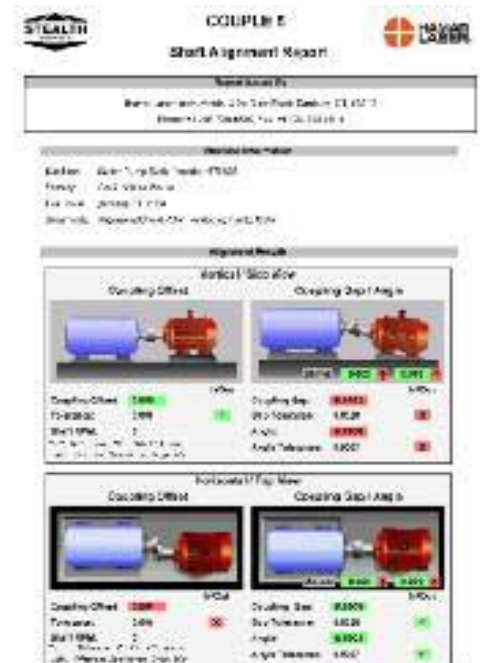

Plug the R-1345 PDA into a PC via ActiveSyn® and any newly saved alignment files are automatically transferred. Simply open the Stealth Report Program, open the file, add comments if needed and print away!

Dual-Beam™ Detector Technology

A patented technology that allows the measurement of center and angle simultaneously with only one PSD, thus eliminating several potential measurement errors when using two PSD's.

Here's how it works:

1. Beam #1 blinks on and hits PSD measuring the center offsets.
2. Beam #1 blinks off for background light correction.
3. Beam #2 blinks on and bounces off one prism, passes through a lens, bounces off a second prism and hits the PSD, measuring the angle.
4. Beam #2 blinks off for a second background light correction.

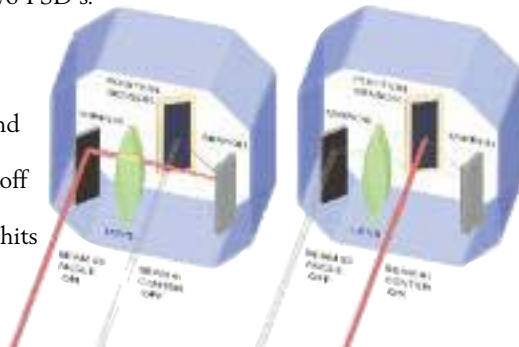

Standard Software Features

- Auto Sweep™
- Thermal Growth/Calculator
- Recommended Tolerances
- 500 Saved Files
- Jack (spacer) Shaft
- Report Software for PC

Optional Software Features

- Uncoupled Mode
- Point Mode
- Bolt Bound™
- Vertical Machines
- User-Defined Tolerances
- Templates
- Repeatability/History
- Train Alignment
- Editing Software

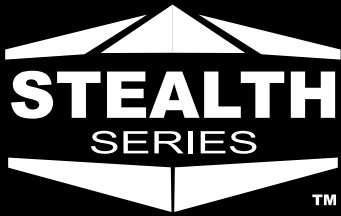

S-670 Specifications

Laser/Target Unit Size	4.2" x 3.3" x 2.2" (107 mm x 84 mm x 55 mm)
Housing Material	Impact resistant plastic
Detector Type & Size	Single-axis super-linear PSD 30 mm (v) x 8 mm (h) provides 2 continuously updating alignment axes.
Target Measurement Resolution	Offset: 1.0 micron (.000039") Angular: 0.02 mm/M (.00024 in./ft.)
Target Measurement Accuracy	Offset: <0.3% Angular: <1.0%
Angular Sensor Range	+/- 5°
Laser Type	650 nm dual-beam laser with horizontal adjustment < 0.9mW
Communication between Target & Data Analyzer	Wireless Bluetooth® 2.4 GHz radio frequency
Communication Range	33 feet (10 M)
Ruggedized Display Platform	PDA
Rotation Sensor (3rd axis)	Accelerometer Resolution: 0.1° Accuracy: +/- 1.0°
Environmental	IP 67 (laser, target and PDA)
Data Storage Capacity	500 files
Bracket Set	Covers 1" (25.4 mm) to 6" (152.4 mm) diameter shafts. Comes with 4" (101.6 mm), and 8" (203.2 mm) posts
Application Range	33 feet (10 M) between laser and target
Operating/Storage Temperature	5°F to 140°F (-15°C to 60°C) for Laser, Target and PDA
Battery Life Target	12+ hours continuous use with Bluetooth® — 13 hours with backup cable. Target can be plugged into power source during use. Battery status icon for both T-1285 Target and PDA.
Battery Life Laser	60+ hours continuous use. Blinking LED indicates low battery status.
Battery Life PDA	15 hours normal use
A/C Battery Charger (Laser, Target and PDA)	110V to 220V with U.S. and European adapters

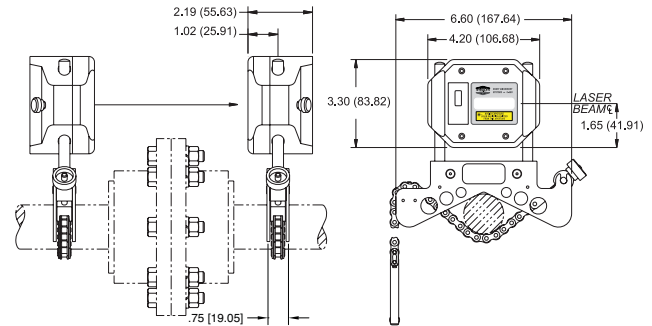

Options

R-1345 PDA Device

Standard PDA Display features Windows® 6.0, high resolution VGA display, ruggedized design, and an environmental rating of IP67.



Bracket & Chain

The A-980 standard bracket and chain set allows alignment of 1" (25.4 mm) to 6" (152.4 mm) diameter shafts. Comes with 4" (101.6mm) and 8" (203.2mm) posts.



Bracket Options

Shown here is the A-982 Magnetic Bracket Adapter. Other options:

- A-980A Chain Bracket Upgrade (6", 12" posts, extra chain)
- A-980B Small Shaft Adapter
- A-980C Extra Chain Set 1"-12" Shaft Diameter
- A-980NRA Non-Rotating Small Shaft Bracket
- A-980NRB Non-Rotating Large Shaft Bracket
- A-980OF Offset Bracket
- A-981 Competitor Adapter Bracket
- A-984 Turbine Bolt Hole Bracket



Hamar Laser Instruments, Inc.
 5 Ye Olde Road, Danbury, CT 06810
 Phone: 800.826.6185 • Fax: 203.730.4611
 Int'l: +1.203.730.4600
 E-mail: sales@hamarlaser.com
 www.hamarlaser.com

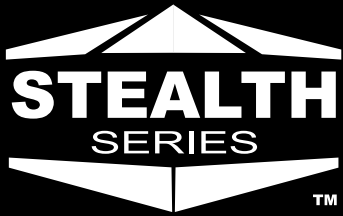

S-680 Stealth Series™ Shaft Alignment Systems

S-680 5-Axis Wireless



**HAMAR
LASER**®
Shaft Alignment Laser Systems



S-680 Wireless 5-Axis Shaft Alignment System

The S-680 is a next-generation shaft alignment laser system and part of the new Stealth Series™ developed by Hamar Laser Instruments, Inc.

The S-680 uses the latest in super-linear PSD technology, wireless communication and innovative design to offer the most feature-rich, accurate, and reasonably priced system on the market today. With over 40 years of laser alignment innovation, our systems can easily be used by the most inexperienced millwright but are also highly advanced for the most experienced users.

Features

- **Bluetooth® Wireless Communication:** Internal Bluetooth transmitter with a range from Target to PDA of up to 33' (10 M).
- **Super-Linear PSD Detector Technology:** Laser industry's highest-resolution, super linear PSD sensor, providing 0.5 micron resolution, 2 alignment axes and a measuring range of 30 mm (V) x 10 mm (H).
- **4-Axis Live Move Screens:** Two offset and two angular alignment axes continuously update, allowing the full alignment at the 12:00 position! Dynamic motor graphics show how much the motor moves as you adjust it.
- **Long Wireless Battery Life:** Laser and target use the latest in lithium polymer battery technology, which offers the industry's longest wireless battery life of over 12 hours of continuous use!
- **Latest Electronic Design:** Both laser and target are newly designed and incorporate the most sophisticated electronics available.

- **Auto Sweep™ Data Taking Mode:** A standard feature, making coupled alignment amazingly easy! Built-in accelerometer detects movement and automatically sends data to the software without pushing any buttons.

The S-680 utilizes our patented Dual-Beam™ PSD Detector technology to provide exceptional accuracy and functionality.

Laser

The S-680 uses patented Dual-Beam™ technology that allows the measurement of offset and angle simultaneously with one PSD, thus avoiding potential measurement errors when using two PSDs.



Target

Target Resolution is 0.5 micron (Offset) and 0.01 mm/M (Angular), with an Angular Sensor Range of +/- 5 degrees.



- **Upgraded Bracket Set:** Kit comes with enough chain to align 1" (25.4 mm) to 12" (304.8 mm) diameter shafts. Comes with 4" (101.6 mm), 6" (152.4 mm), 8" (203.2 mm) and 12" (304.8 mm) posts. With our optional A-981 Adapter Bracket you can use the S-680 on our competitor's standard brackets!
- **Ruggedized PDA:** High resolution screen, 15-hour battery life and 512 MB of memory. Options include Digital Camera, Bar Code Scanner, GPS, AA Battery Module, Wireless LAN and many more.

- **Uncoupled Mode:** Utilizing the Auto Sweep™ function, uncoupled alignments are fast and easy: rotate the laser to any point, sweep the target by, and the software automatically records the measurement.
- **Fully Loaded System:** Standard and optional features of the S-670 system (except Train Alignment), plus the A-980A Chain Bracket Upgrade.
- **High Accuracy:** Up to 10x higher PSD accuracy than our competitors, the S-680 gives you the most accurate measurement on the market.
- **Optional Ruggedized Tablet Display:** Windows®-based tablet with large screen and Couple6 Software.

Standard Hardware

- Bluetooth® Wireless Communication
- 0.5 Micron Resolution
- <0.15% Offset Measurement Accuracy
- 30 mm x 10 mm 2-Axis PSD
- New Lithium Polymer Battery Technology
- 12-Hour Wireless Target Battery Life
- Dual-Beam™ Technology
- State-of-the-Art Electronics
- Ruggedized PDA with 15-Hour Battery Life and IP67 Rating
- Upgraded Bracket Set for 1" to 12" (25.4 mm to 304.8 mm) Shaft Diameters

Optional Hardware

- Magnetic bracket
- Offset bracket
- Non-rotating shaft bracket
- Bolt-hole bracket
- Small-shaft adapter
- Stealth interactive training video

The Best Choice in Shaft Alignment is Easy To See

Easy-to-Follow Screens Lead You Through the Alignment



Select Machine – Select alignment and coupling type.



Dimensions – Enter only 4 motor dimensions for automatic shim value calculation during the alignment.



Soft Foot Results – Easy to follow procedure for checking Soft Foot, a common problem that can cause many alignment problems.



Take Readings – 4 data taking modes for maximum flexibility and ease of use: Autosweep™ Mode, Point Mode, Uncoupled Mode or Clock Mode.

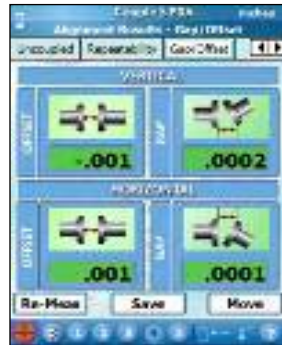

Results Screen – Shows misalignment results instantaneously. Green means in tolerance and red means out of tolerance.



Move Screen – Live in both offset and angular axes, the Move Screen instantaneously shows the movement of the motor during alignment making it easy to align the motor.

Sample Report



Plug the R-1345 PDA into a PC via ActiveSync® and any newly saved alignment files are automatically transferred. Simply open the Stealth Report Program, open the file, add comments if needed and print away!

Dual-Beam™ Detector Technology

A patented technology that allows the measurement of center and angle simultaneously with only one PSD, thus eliminating several potential measurement errors when using two PSD's.

Here's how it works:

1. Beam #1 blinks on and hits PSD measuring the center offsets.
2. Beam #1 blinks off for background light correction.
3. Beam #2 blinks on and bounces off one prism, passes through a lens, bounces off a second prism and hits the PSD, measuring the angle.
4. Beam #2 blinks off for a second background light correction.

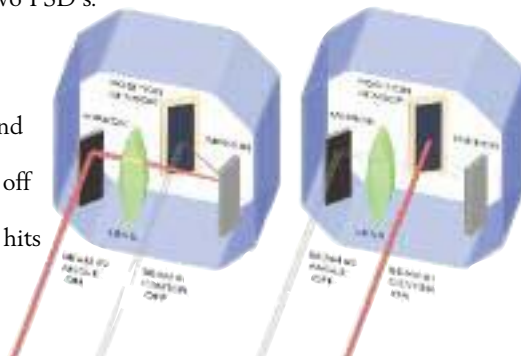

Standard Software Features

- Auto Sweep™
- Uncoupled Mode
- Point Mode
- Bolt Bound™
- Vertical Machines
- Horizontal Machines
- Soft Foot
- Thermal Growth/Calculator
- Recommended Tolerances
- User-Defined Tolerances
- Templates
- 1000+ Saved Files
- Jack (spacer) Shaft
- Repeatability/History
- Report Software for PC

Optional Software Features

- Train Alignment
- Editing Software

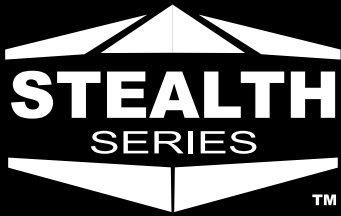

S-680 Specifications

Laser/Target Unit Size	4.2" x 3.3" x 2.2" (107 mm x 84 mm x 55 mm)
Housing Material	Impact resistant plastic
Detector Type & Size	Two-axis super-linear PSD 30 mm (v) x 10 mm (h) provides 4 continuously updating alignment axes.
Target Measurement Resolution	Offset: 0.5 micron (.00002") Angular: 0.01 mm/M (.00012 in/ft.)
Target Measurement Accuracy	Offset: <0.15% Angular: <0.75%
Angular Sensor Range	+/- 5°
Laser Type	650 nm dual-beam laser with horizontal adjustment <0.9mW
Communication between Target & Data Analyzer	Wireless Bluetooth® 2.4 GHz radio frequency
Communication Range	33' (10 M)
Ruggedized Display Platform	PDA, laptop or tablet PC
Rotation Sensor (5th axis)	Accelerometer Resolution: 0.1° Accuracy: +/- 1.0°
Environmental	IP 67 (laser, target and PDA)
Data Storage Capacity	1,000+ files, limited only by hardware storage capacity
Upgraded Bracket Set	Covers 1" (25.4 mm) to 12" (304.8 mm) diameter shafts. Comes with 4" (101.6 mm), 6" (152.4 mm), 8" (203.2 mm), 12" (304.8 mm) posts, two 17.25" (438 mm) chains and two 60" (1,524 mm) chains
Application Range	33' (10 M) between laser and target
Operating/Storage Temperature	5°F to 140°F (-15°C to 60°C) for Laser, Target and PDA
Battery Life Target	12+ hours continuous use with Bluetooth® — 13 hours with backup cable. Target can be plugged into power source during use. Battery status icon for both T-1290 Target and PDA.
Battery Life Laser	60+ hours continuous use. Blinking LED indicates low battery status.
Battery Life PDA	15 hours normal use
AC Battery Charger (Laser Target & PDA)	110V to 220V with U.S. and European adapters

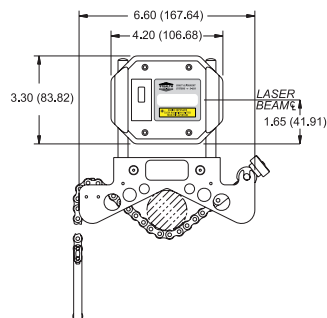

.75 [19.05]

Options

R-1345 PDA Device
Standard PDA Display features Windows® 6.0, high resolution VGA display, ruggedized design, and an environmental rating of IP67.



R-1342 Ruggedized Tablet

Standard tablet features Windows® XP or Vista®, high resolution touch screen, ruggedized design, and an environmental rating of IP65.



Bracket & Chain

The A-980 standard bracket and chain set allows alignment of 1" (25.4 mm) to 6" (152.4 mm) diameter shafts. Comes with 4" (101.6mm) and 8" (203.2mm) posts.



Hamar Laser Instruments, Inc.
5 Ye Olde Road, Danbury, CT 06810
Phone: 800.826.6185 • Fax: 203.730.4611
Int'l: +1.203.730.4600
E-mail: sales@hamarlaser.com
www.hamarlaser.com